

Series 8202 ... Cast Iron
Series 8215 ... Cast Steel

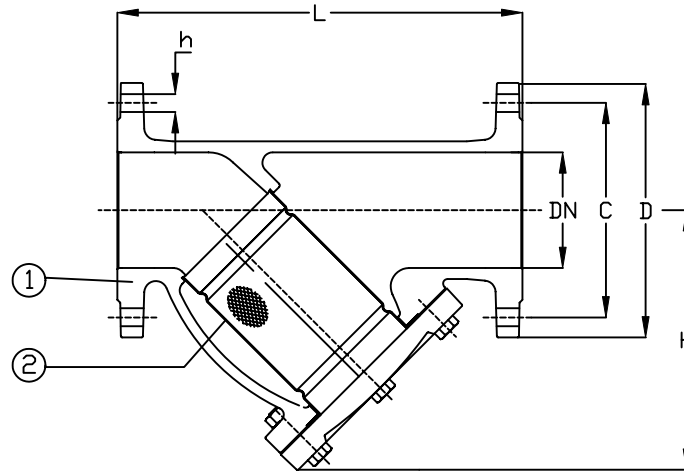

Face to Face according to DIN 3202-F1
Flanges according to DIN2501-PN16

Part Nr.	Material	Code	Size DN	Nom. Pressure PN	Hydraulic Inspection	
					Body	Seat
1 - Body 2 - Strainer	Cast Iron Stainless Steel	GG25 AISI 304	15 to 150	16	25	16
1 - Body 2 - Strainer	Cast Steel Stainless Steel	GSC-25N AISI 304	15 to 150	40	64	40

Size	L	H	DIN PN16					DIN PN40					Steel Kg	Iron Kg	
			D	C	No.	h	t	D	C	No.	h	t			
015	130	75	Same as DIN PN40					14	95	65	4	14	16	4	3.5
020	150	75	Same as DIN PN40					16	105	75	4	14	18	5	4.5
025	160	90	Same as DIN PN40					16	115	85	4	14	18	6	5
032	180	90	Same as DIN PN40					16	140	100	4	18	18	8	7.2
040	200	110	Same as DIN PN40					16	150	110	4	18	18	10	9
050	230	120	Same as DIN PN40					18	165	125	4	18	20	13	11.5
065	290	140	Same as DIN PN40					18	185	145	8	18	22	19	17
080	310	170	Same as DIN PN40					20	200	160	8	18	24	24	22
100	350	220	220	180	8	18	20	235	190	8	22	24	35	32	
125	400	260	250	210	8	18	22	270	220	8	25	26	51	48	
150	480	300	285	240	8	22	22	300	250	8	25	28	71	67	